

Rocon Water Control Valve

FOR RESISTANCE WELDING



Universal Flow Monitors

Rocon Water Control Valve

Improve robotic weld quality and extend equipment life using Rocon Water Control Valve

Rocon Water Control Valve (WCV) prevents leaks and defective welds in the resistance welding process. This is done by shutting off the water flow to a displaced weld cap. The operator is then made aware of this condition by an electrical signal and optional LED lights. Features include:

- Reduces downtime and costly maintenance for cleanup upon cap displacement
- Alarms and shuts off water in less than 1/2 a second
- Prevents bad welds by showing low flow via indication and switch alarm
- Lengthen cap life by showing insufficient flow
- Reduce down time by viewing flow rate during operation
- Bypass not required when waiting for maintenance
- Fast replacement using modular/subplate construction
- No orifice to clog
- One size fits all (.5 - 3 GPM)
- Low pressure drop (less than 2 PSI at 1 GPM)
- Operates anywhere, with open or closed systems
- Operation mode indicator lights optional
- Remote restart/backflush
- Refined plant tested design

MECHANICAL

Pressure drop at 1 GPM	2 PSI	13.8 kPA
Maximum water flow:	.5 - 3 GPM	2-12 LPM
Minimum water flow:	.5 of a gallon	2 LPM
Maximum water temperature:	180°F	82° C
Minimum water temperature:	35°F	1.7° C
Maximum operating pressure supply:	Port #1, 100 PSI	68.9 kPA
Minimum operating pressure supply:	Port #1, 10 PSI	68.9 kPA
Maximum operating pressure return:	Port #4, 50 PSI	344.7 kPA
Minimum operating pressure return:	Port #4, 5 PSI	34.5 kPA
Maximum pressure differential:	Port #1 and #4, 50 PSID*	344.7 kPA
Minimum pressure differential:	Port #1 and #4, 5 PSID	34.5 kPA
Manual restart - maximum pound force:	100 pounds	45 Kg
Air restart - air valve:	2 position, 3 way, NC	
Air restart - maximum air pressure:	100 PSI	689 kPA
Air restart - minimum air pressure:	NOTE: RETURN WATER PRESSURE PORT #4 CANNOT BE MORE THAN 15 PSI HIGHER THAN AIR RESTART PRESSURE	
Weight - manual restart:	11.5 lb	5.2 Kg
Weight - air restart:	11.5 lb	5.2 Kg

*Higher pressure differential consult factory.

ELECTRICAL

Three-wire switch:	SPDT 15 amps, 125/250/480 vac; 1/8 hp, 125 vac; 1/4 hp 250 vac; 1/2 amp, 125 vdc; 1/4 amp, 250 vdc. UL code L96
Indicator lights:	AC - 120 V Red / Green Yellow DC - 24V Red / Green Yellow
Air coil:	AC - 120V / 50 Hz - 60 Hz, 1/4 amp inrush / 5 watts. DC - 24V, 1/2 amp inrush / 6.2 watts.

CONSTRUCTION MATERIALS

Housing:	Brass
Valve internal metal parts:	Shaft, handle, spring, screws, lock washers and washers; stainless steel.
Plastic parts:	Covers, cartridge, spools, indicator arm and air piston assembly; Ryton, CPC, or Polysulphone.
Seals:	All Seals are Buna N
Air restart:	All Seals are Buna N
Valve external metal parts:	Screws and lock washers 18-8 stainless steel
Switch box:	Anodized Aluminum
Window:	Lexan
Air lockout:	Latch, spring = SS

How It Works

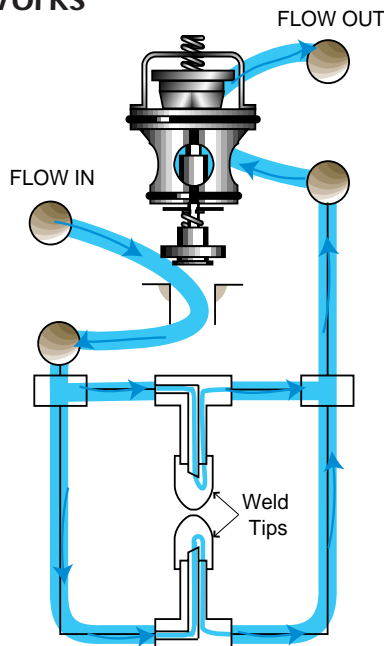

Water flows through the valve to the weld tips. Return flow holds the valve opened.

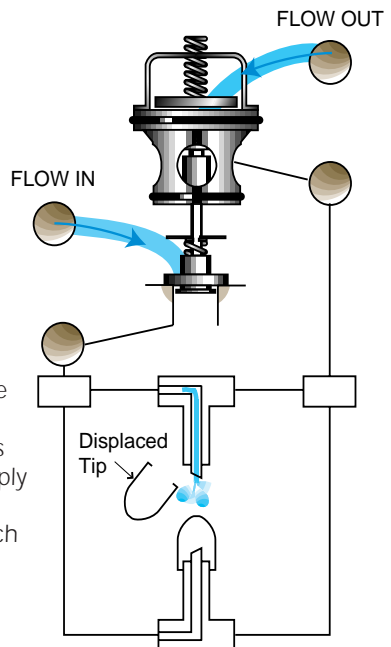

Weld tip displacement causes valve to close which immediately shuts off the water supply and return. This actuates the switch alarm. Minimum leakage of 2 oz. or less occurs.

Sub-Plate Style

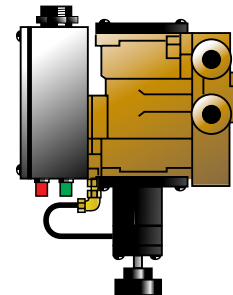
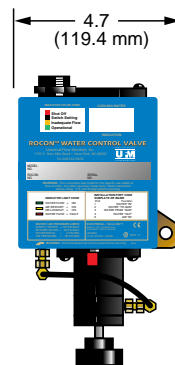
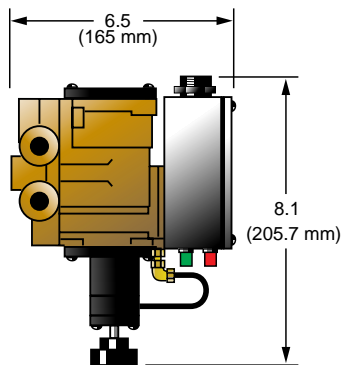

In-Line Style

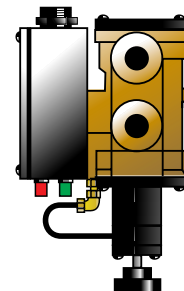
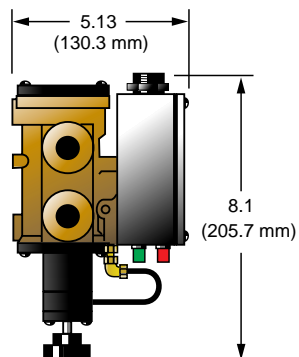

HOW TO ORDER

Select appropriate symbols and build a model code number, as in example shown:

Example:

WCV - S - 4 - H - 7 - A3N5 - A - L - ** - *******

SERIES
Water Control Valve = **WCV**

STYLE
Inline = **I**
Valve body (w/subplate) = **S**
Valve body only = **B**
Subplate only = **M**

PORT SIZE
Styles I, S or M (1/2 NPTF) = **4**
Styles I, S or M (3/4 NPTF) = **6**
Style B (Valve body w/o subplate) = **0**
Subplate only, "M" style order code ends here.

CARTRIDGE SIZE
INLINE or SUBPLATE
GPM PSIG-Differential
1/2-3 Low to High = **H**
Consult factory for greater flow ranges

ASSIST SPRING RATE
1x-4x Spring Rate (10-90 PSIG) = **7***
* Can only be used w/ adj shutoff option

Control Number If Required

DESIGN NUMBER
Factory to provide at time of quote
(internal reference only)

OPTIONS
LOCKOUT, MANUAL = **L****
** Lights option "C" must be selected

VOLTAGE
120 V AC = **A**
24 V DC = **D**

1- RESTART		3- LIGHTS	
Manual = M	Air = A	No lights = N	ON (Green) / OFF (Red) = A
Air with Electrical Interchange = E		ON (Green) / OFF (Red) With Lockout (Yellow) = C**	**Optional lockout must be selected
2- READOUT SWITCH		4- ELECTRICAL CONNECTOR	
3 Wire SPDT = 3		No Receptacle = N	4 Pin = 4
		5 Pin = 5	7 Pin = 7

Question ? Call the Factory 248-542-9635 or Fax 248-584-1490.
Information needed:
New Valve : 1 -What is the cooling water (GPM) needed per weld gun arm, 2 -What is body shop Supply Water Pressure?, 3 -What is body shop Return Water Pressure?, 4 -What is Supply and Return Water Pressure at Robot Cell fence line?, 5 -Is Mini Connector required for electrical hook up?, 6 -If Yes, how many pins, we will need wiring diagram if factory standard is not used. 7 -AC or DC?.
Spare Parts : Model Code Number and N Number required. They are located on Switch Box Cover.

UNIVERSAL FLOW MONITORS

1755 E. Nine Mile Road • P.O. Box 249 • Hazel Park, MI 48030

Tel 248-542-9635 • Fax 248-398-4274

WWW <http://www.flowmeters.com/> • E-Mail ufm@flowmeters.com

